

### DESCRIPTION

- Metal construction with Chrome plated, or Matt black, Opal Black, Copper

### STANDARD

- Comply with GB1560-2017
- All finishes pass AASS 24H grade 10.

### WARRANTY

- 1 year limited warranty except artificial damage and chemicals erosion

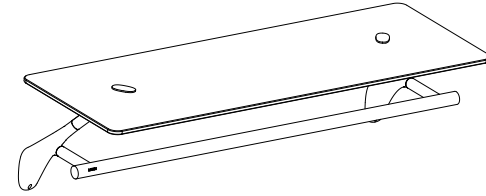
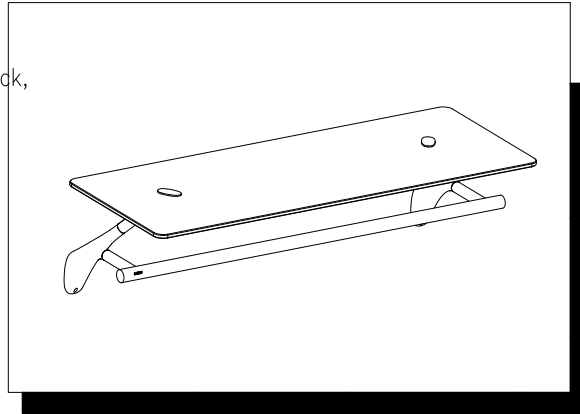

NOTE: ALL DIMENSIONS ARE MM.

DOUBLE TOWEL SHELF  
Models: ACC2601 SERIES

